



© Copyright by Meyle Products Gaertner GmbH



MEYLE[®]
Products

**Tie rod end
left / right**

MEYLE No. 616 020 6002/HD
Reference No. 1603 215

Exceeds OE Specifications
For information please check www.meyle.com or contact your sales person

Tie rod end to fit **Opel Astra G, Zafira**

The Astra and Zafira are successful cars for Opel, as indicated by the quantities sold. Even so, these vehicles have typical weak points, such as the tie rod end. It soon draws attention to itself in a negative sense with rattling noises or with too much play seen during servicing.

The reason for this is the relatively small diameter of the ball head. The ball head causes too much wear in the mount shell because of the relatively high surface pressure.

MEYLE's answer is a ball head with a larger circumference to reduce the surface pressure. With this progressive quality improvement, we guarantee a mature component with a much longer service life.

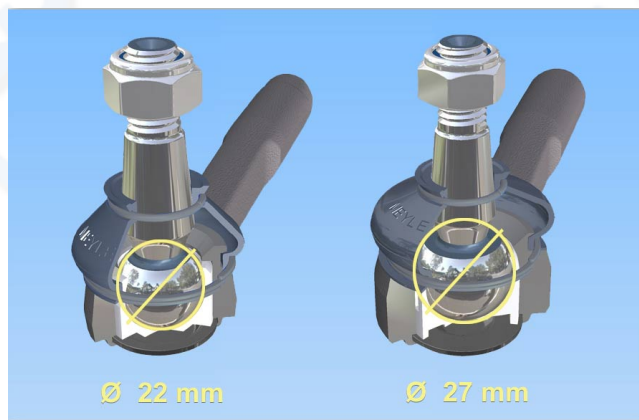

MEYLE - Miles in Motion