

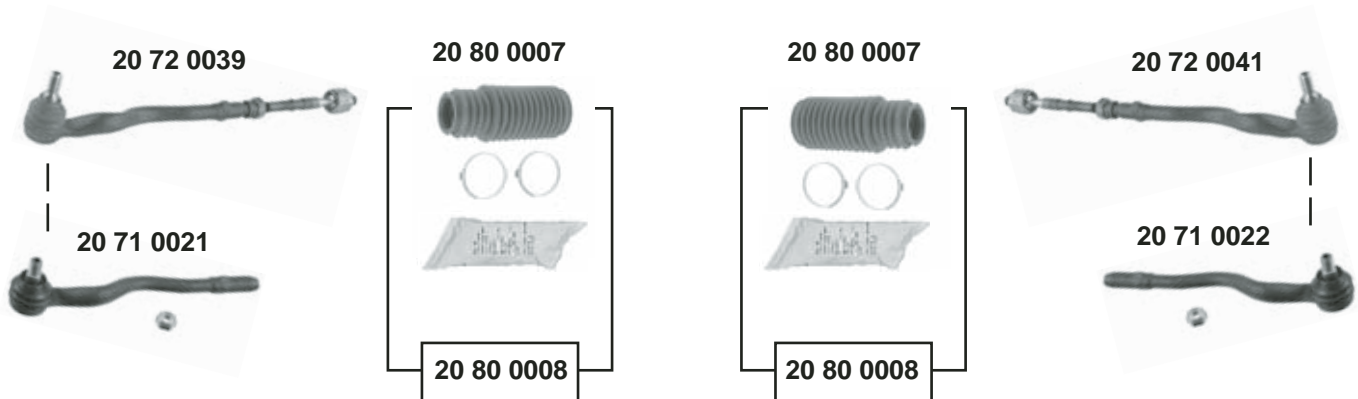



3'er (E46)
(1997 →)

316 i → 330 i
(ex.) 325 xi / 330 xd / 330 xi



	Ref. - No.			
20 71 0021	32 21 1 095 957	Spurstangenendstück / tie rod end		M14x1,5 RHT
20 71 0022	32 21 1 095 958	Spurstangenendstück / tie rod end		M14x1,5 RHT
20 72 0039	32 11 1 096 897	Spurstange / tie rod	09/98 →	L 430
20 72 0041	32 21 1 096 898	Spurstange / tie rod	09/98 →	L 430
20 80 0007	32 13 1 092 876	Lenkmanschette / steering boot	09/98 →	
20 80 0008	32 13 1 096 910 S1	Rep. Satz Lenkmanschette / rep. kit steering boot	09/98 →	



3'er (E46)
(1997 →)

316 i → 330 i
(ex.) 325 xi / 330 xd / 330 xi

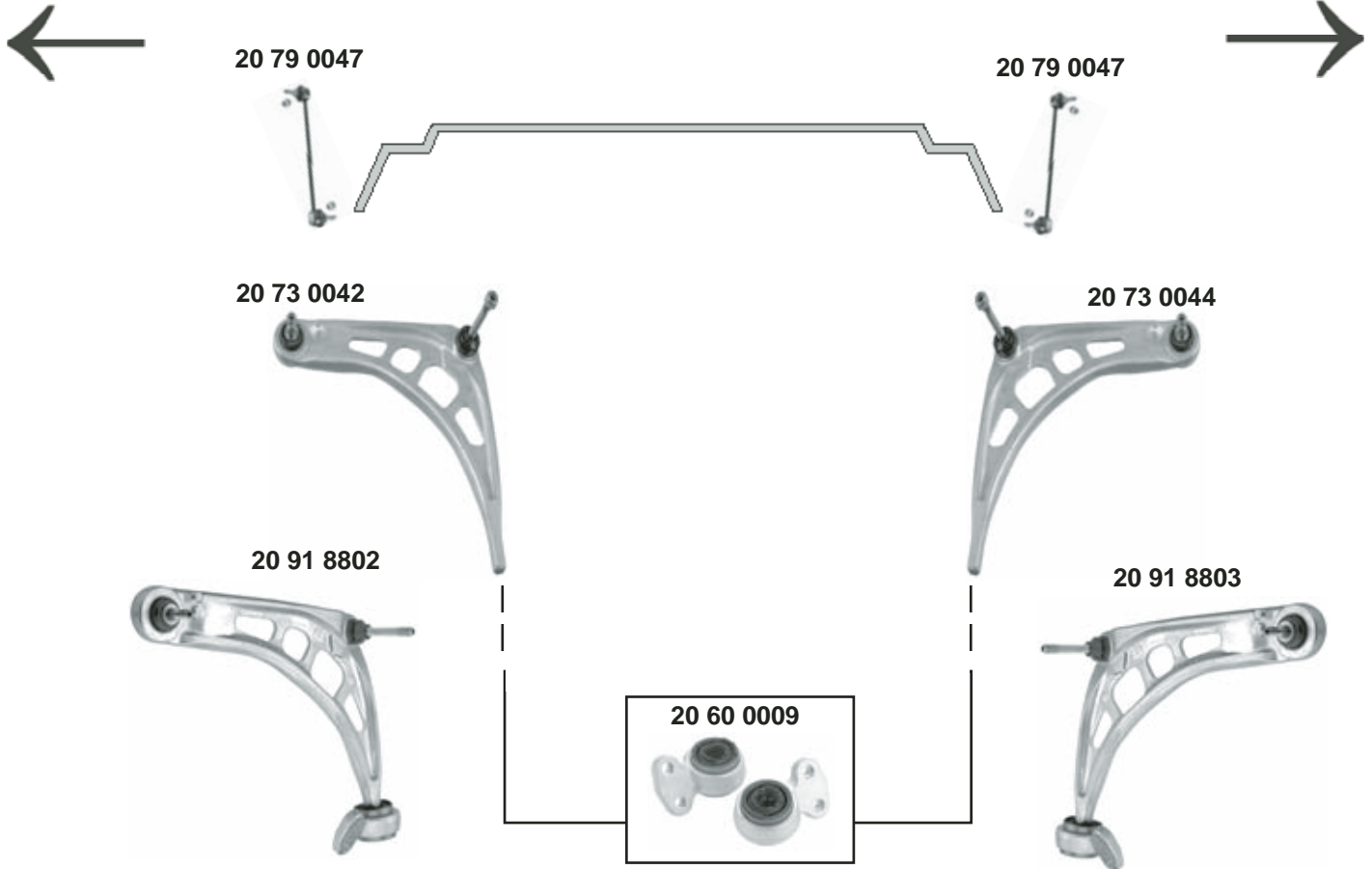

(1) bei Erneuerung eines kompletten Halters ist die andere Seite mit auszutauschen (SWAG 20 60 0009 verwenden); ein vorher montiertes Gummilager darf nicht wiederverwendet werden, da die Innenhülse durch das trockene Abziehen zerstört wird!
Querlenker mit der Form A sind auszutauschen, nicht mischen!!
When replacing a complete retainer please do also think of the other side - this has to be replaced as well (use SWAG 20 60 0009). A rubber mounting installed before may not be used anymore as the rubberized interior is destroyed by the dry pulling off.
Control Arms Form A have to be replaced, do not mix!!

alte Ausführung/old execution

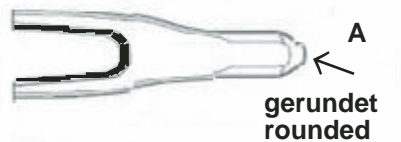

neue Ausführung
new execution



Ref. - No.



20 60 0009	31 12 6 757 623	Rep. Satz Querlenker / rep. kit control arm	(1)	L 270
20 73 0042	31 12 6 758 519	Querlenker / control arm	(1)	
20 73 0044	31 12 6 758 520	Querlenker / control arm	(1)	
20 79 0047	31 35 1 095 694	Verbindungsstange / connecting rod	(1)	
20 91 8802	31 12 6 758 519 S1	Querlenker / control arm	(1)	
20 91 8803	31 12 6 758 520 S1	Querlenker / control arm	(1)	